

TRADING TECHNIQUES

# Market Profile Basics

*Every off-floor trader would like to get a feel for how things really are on the exchange floor. Mastering Market Profile may help you get it.*

by Jayanthi Gopalakrishnan



W

orried that you'll never be able to compete with the floor traders? After all, they're right there in the middle of the action. They're privy to information that off-floor traders see late or maybe never. Once you start using Market Profile, however, you may find yourself with *more* information than the floor trader. No longer will floor traders, decked out

in their colored jackets, frantically gesturing and scrambling to make themselves heard and seen by other traders, seem chaotic, intimidating, or bizarre. Instead, with the use of Market Profile, you will see the order in the markets.

J. Peter Steidlmayer developed Market Profile in the 1980s in conjunction with the Chicago Board of Trade. Traders who use it say that they get an in-depth understanding of the market, contributing to improved trading. Many factors can be monitored from Market Profile.

Market Profile is not an indicator in the typical sense. It does not provide buy/sell recommendations but acts more like a decision-support tool. It organizes the data so that you can understand who is in control of the market, what is perceived as fair value, and the direction of the price move. It is possible to extract enough information from Market Profile for you to position your trades more advantageously.

Market Profile is useful for the pit trader as well as the off-floor trader. The indicator can help the off-floor trader get a better sense of the market; prior to the introduction of Market Profile, only floor traders had access to this information. Although all references here refer to using futures contracts, Market Profile can be used just as effectively for other tradables. Software vendors such as Cqg and WindoTrader provide Market Profile displays for equities.

## IN THEORY

The concept of Market Profile stems from the idea that markets have a form of organization determined by time, price, and volume. Each day, the market will develop a range for the day and a *value area*, which represents an equilibrium point where there are an equal number of buyers and sellers. In this area, prices never stay stagnant. They are constantly diverging, and Market Profile records this activity for traders to interpret.

Market Profile is based on the normal distribution curve, wherein approximately 70% of the values fall within one

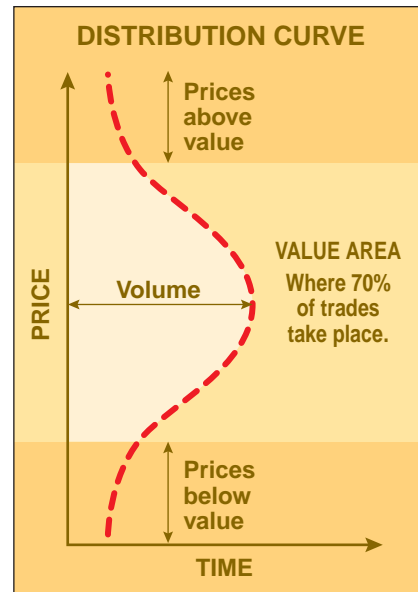

**FIGURE 1: MARKET PROFILE STRUCTURE.** The structure of Market Profile follows that of a normal distribution curve of price occurrences.

standard deviation of the average. If you rotate the normal distribution curve so that price is along the vertical axis and time on the horizontal axis (as shown in Figure 1), you have the structure of Market Profile.

A normal distribution curve assumes that the number of occurrences follow a bell-shaped curve. Anyone who has traded in the markets, however, knows that prices never follow a definite pattern; in fact, you rarely see a normal distribution. What you *do* see are skewed distribution of prices, which makes it possible to see the price at which most of the trades actually took place. This provides significant clues about the direction of prices and is the groundwork for understanding Market Profile. In theory, this helps the trader identify where prices are in relation to values.

Monitoring price distribution over time gives insight into what levels are considered fair and unfair. You may take advantage of this information and identify good trading opportunities.

Volume is the key to understanding Market Profile. If prices move away from the value area but volume starts to dry

4590 F  
 4586 F  
 4584 DF  
 4582 DF  
 4580 DE  
 4576 DE  
 4574 YDE  
 4572 YDE  
 4570 YDE  
 4566 YDE  
 4564 YDE  
 4562 YDE  
 4560 YDE  
 4554 YDE  
 4552\* YD  
 4550 YD  
 4544 D  
 4540 D

DOUBLE-DISTRIBUTION DAY  
 Oct '99 crude oil (CEC-NYM), 8/31/99

PRICE RANGE

2230 G  
 2225 G  
 2224 GKL  
 2223 GKL  
 2222 GKL  
 2221 GKL  
 2220 GKL  
 2219 GKL  
 2218 GJKL  
 2217 GJKL  
 2216 GJKL  
 2215 FGJKL  
 2214 FGJKL  
 2213 FGJKL  
 2212 FGHIJL  
 2211 FGHIJL  
 2210 FGHIJL\*  
 2209 FGHIJL  
 2208 FGHIJL  
 2207 FGHIJL>  
 2206 FGH  
 2205 F  
 2204 F  
 2203 F  
 2202 F  
 2201 F  
 2200 BF  
 2199 BF  
 2198 BDEF  
 2197 BCDEF  
 2196 BCDEF  
 2195 BCDEF  
 2194 BCDEF  
 2193 BCDEF  
 2192 BCDEF  
 2191 BCDEF  
 2190 BCDEF  
 2189 BCDEF  
 2188 BCDEF  
 2187 BCDE  
 2186 BCDE  
 2185\* BCE  
 2184 BCE  
 2183 BCE  
 2182 BE  
 2180 B  
 2179 B  
 2178 B  
 2154 B



up, it is likely that prices will move back to the value area. Such a movement indicates that sellers are not happy that prices are below value and buyers are not happy that prices are above value. Trading activity may increase only when prices return to the value area.

If, on the other hand, prices diverge from the value area with increasing trading activity, that indicates market participants are reevaluating their idea of value. By observing market activity through Market Profile, you can get a grasp of who is in control of the market and determine which way the market is likely to move.

**WATCHING IT DEVELOP**

The development of Market Profile can be seen during the course of the trading day in Figure 2. Market Profile is made up of *time price opportunities* (Tpos), which are represented by letters. Each letter represents one half-hour of the trading day (but beware that the letters used to represent time periods are not consistent across vendors). In the example in Figure 2, the periods are represented with letters A to J, with A being the first half-hour.

The first hour of trading sets the general pattern for the day and is your first opportunity to view market activity. This period is important for determining what the floor traders are doing; those traders are trying to find a price at which both the buyer and seller agree to make a trade. There are two broad categories of market participants: the *day-timeframe trader* and the *other-timeframe trader*. The floor trader is referred to as the day-



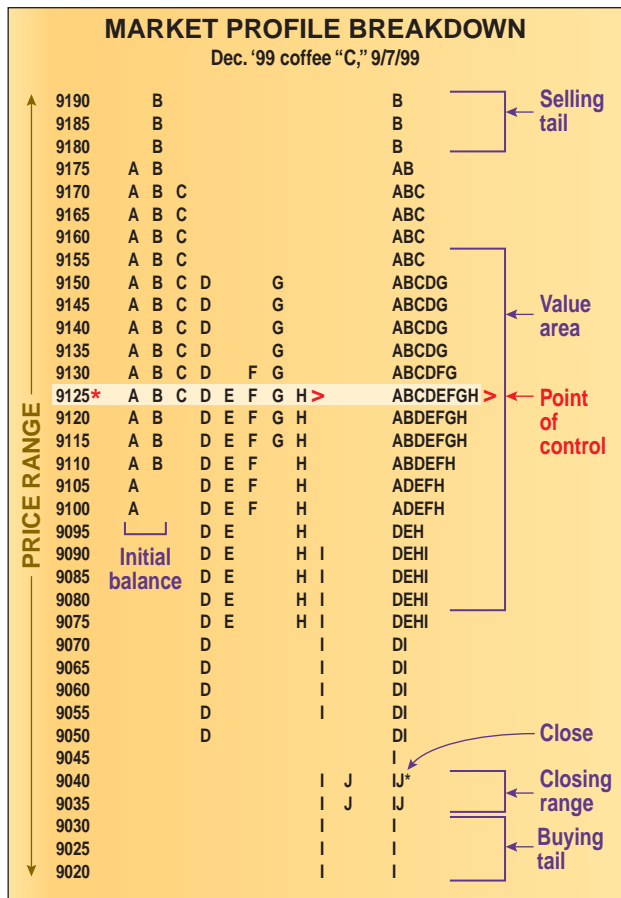

**FIGURE 2: MARKET PROFILE BREAKDOWN.** Market Profile is made up of time price opportunities (TPOs), which are represented by letters. Each letter represents one half-hour of the trading day and is placed at each price level occurring during that time.

timeframe trader and all others as other-timeframe. The latter trader type provides market direction by moving prices to new levels, whereas the former is interested in trading large volumes on few ticks. They provide liquidity to the markets.

The *initial balance* is the price range of market activity during the first hour (the first two time periods). In Figure 2, this is represented by A and B. On September 7, 1999, the initial balance for the December 1999 coffee contracts was established in the first two half-hour periods between \$91.00 and \$91.90. A wide initial balance suggests that prices will stay within the range, whereas a narrow one suggests that prices may extend beyond it. The ability to differentiate between the two will only be possible after some experience. If the price range falls outside the the range set by the initial balance, there is the suspicion that the other-timeframe trader has entered the market and tried to move prices away from the area of balance.

During D period, the other-timeframe seller entered the market and drove prices lower. However, during the subsequent periods, buyers entered the market and drove prices higher. In H, the seller entered again and held control till the close, as can be seen by the activity during I and J periods.

The height of the entire profile — that is, the high to the low — is known as the *range*. In this example, the range is \$90.20 to \$91.90, which is wider than the initial balance.

On occasion, prices go above or below the initial balance. This is known as a *range extension*. In this example, the range extends below the initial balance, indicating a seller range extension.

The price range where 70% of the trading activity takes place, one standard deviation from the mean, is the *value area*. In this example, it is the area between \$90.80 and \$91.55. Calculation of this area is covered in more detail in the sidebar, “Value area calculation.” This is where the bell curve comes in. The value area reflects the acceptance level of a certain price range or balance area. Any attempt to move prices away could provide important clues to direction.

The *point of control* is the longest line of Tpos closest to the center of the range. In Figure 2, \$91.25 represents the point of control. This is where most of the trading activity took place and is considered to be a fair value for the trading day.

J period is the *closing range* and designates the day’s close. Here, it is \$90.40. The closing price is important because you need it as a reference point for the following day’s opening activity.

When you have a series of single letters on either extreme, it is known as a *single-print buying/selling tail*. The presence of such a tail indicates a strong reaction by the other-timeframe traders. In this case, both single-print buying and selling tails are present. Since both are very short — only three letters — the response from the other-timeframe traders was very strong. The buying tail represented by the three I periods shows that the other-timeframe buyer responded quickly to lower prices. Conversely, the three Bs at the top of the profile indicates that the other-timeframe sellers responded quickly when the prices were above value.

### RECOGNIZING DIFFERENT DAYS

Now that you know how a profile develops, it’s time to examine the different types of days you might encounter. There are several types of profiles, and you should be able to recognize the shapes associated with the different types of

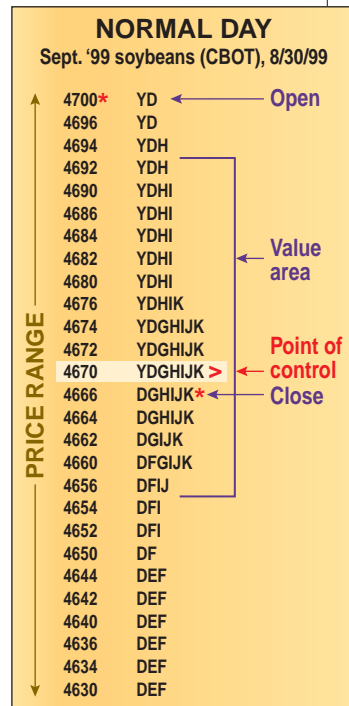

**FIGURE 3: PROFILE OF A NORMAL DAY.** A wide initial balance and a relatively balanced market characterize a normal day. The TPOs are represented by DEFGHIJK. The Y period represents trading prior to the open.

### VALUE AREA CALCULATION

Value area can be calculated using either volume or time price opportunity (TPO) count. Here's the calculation using the TPO count:

- 1 Count the total number of TPOs, including single prints.
- 2 Calculate 70% of this number.
- 3 Identify the point of control (the longest line of TPOs closest to the center of the range) and note its TPO count.
- 4 Add the TPOs of the two prices above and below the point of control. The TPOs of the two with the greater number should be added to the TPOs of the point of control.
- 5 Continue this process till the total number of TPOs counted reaches 70% of the total number of TPOs.

The same methodology can be used to calculate the value area using volume. See sidebar Figure 1 for the application of the calculation.

Total TPOs = 131

70% of 131 = 91.7

TPOs of the point of control = 11

TPO count:  $11 + 20 + 18 + 16 + 14 + 9 + 6 = 94$

Value area = \$21.48 to \$21.59

—J.G.

VALUE AREA CALCULATION		
Oct. '99 crude oil, 8/24/99		
2165	C	
2164	CE	
2163	CE	
2162	BCDE	
2161	BCDE	
2160	BCDE	
2159	BCDE	
2158	BCDEJ	9
2157	BCDEFJK	
2156	BCDEFGIJK	16
2155	BCDEFGHIJKL >	11
2154	BCDFGHIJKL	
2153*	BCDFGHIJKL	20
2152	BCFGHIJKL	
2151	BCFGHIJKL	18
2150	BCFGHIKL*	
2149	BCFIKL	14
2148	BCFIKL	6
2147	BIL	
2146	BIL	
2145	BIL	
2144	BI	
2143	BI	
2142	BI	
2141	BI	
2140	BI	
2130	I	

SIDEBAR FIGURE 1: VALUE AREA CALCULATION. The value area is calculated using the TPO counts at price levels above and below that level with the most TPOs.



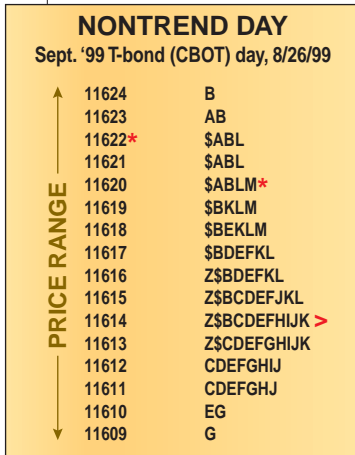

**FIGURE 7: NONTREND DAY.** A narrow trading range with a wide profile identifies this profile. It is likely that traders are waiting for a news event or economic release, or it may be a day prior to a holiday. Here, the TPO symbols are Z\$ABCDEFHIJKL.

useful in indicating price direction. Figure 5 gives an example of a standard trend day; price is consistently rising and there is no interest in moving it in the opposite direction. The profile is usually narrow, with no time period containing more than five Tpos. The other-timeframe participant is in control.

A double-distribution day is displayed in Figure 6. You can clearly see the two different distributions that occurred during the trading day. The initial balance is represented by the B and C Tpos and is relatively narrow, which means that the other-timeframe participant has not

entered the market. The other-timeframe buyers enter the market aggressively during F because they believe prices are below value. This results in the prices extending to another level. Trading between buyers and sellers occurs at this stage, and a new balance level is established.

If you detect the formation of the double-distribution day early, you can take advantage of some great trading opportunities. It is important to watch the Tpos here between the two distributions. They are usually single prints, but if you notice them changing to double prints later during the trading day, it is an indication that price levels are not being sustained at the second distribution; they are, in fact, moving back to the first distribution.

There are days when there will be no enthusiasm that you can observe in the market. You will be able to identify this by a very narrow trading range with a wide profile (Figure 7); no evidence of a range extension is apparent. This is known as a *nontrend day*. What may be happening here is that traders are waiting for either a news event or an economic release, or it could just be a day prior to a holiday. Usually, a nontrend day is followed by a change in trend. In Figure 8, you can see that the profile of the September 1999 Treasury bond contracts, which traded on August 26, 1999, was followed by a downward trend.

There is another type of day known as the *neutral day*. In this case, as the name suggests, there is not much difference in the perception of value between buyers and sellers. You can see that both buyers and sellers are active by the range extensions on either side of the initial balance. Figure 9 represents such a day. The close is in the middle of the range, indicating that there is a balance between the buyer and seller. If, however, the close was near either extreme, it may mean that the buyer (if it closed toward the top) or seller (if it closed toward the bottom) is in control.



**FIGURE 8: IMPLICATIONS OF A NONTREND DAY.** A nontrend day is usually followed by a change in trend. From the bar chart, you can see that the nontrend day that occurred on August 26 was followed by a downtrend. Figure 7 also displays the profile for September 1999 Treasury bond contracts traded on August 26. Since they are from different sources, however, the TPO letters and price increments do not coincide.

### USE IT

After you gain some experience in analyzing Market Profile, you should be able to recognize the different types of days and predict the direction of the price. After you understand how to recognize the different days, you will need to put it all in perspective to see what Market Profile reveals and how traders can benefit from it.

Market Profile is different from a tick chart. It combines price, volume, and time and organizes those factors into a form that you will be able to recognize. A tick chart gives you an idea of the relationship between price and volume at a specific time. By observing Market Profile, you will be able to visually determine the price levels at which the markets are in equilibrium. You will also understand who is in control at any given time and recognize when that control shifts. This gives you an edge in making good trading decisions, alerting you to the possibility of a shift in the perception of value.

The auctioning process in the markets is similar to that of any business: supply and demand. In the futures pits, when

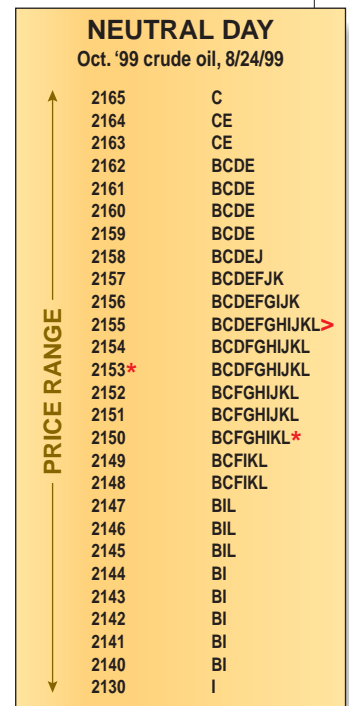

**FIGURE 9: NEUTRAL DAY.** Here, both buyers and sellers are active and they are in agreement on the value of the contracts. Since the close is in the middle of the profile, it indicates that there is balance between the buyers and sellers.



other-timeframe buyers and sellers conduct a transaction, the process goes through a middleman or the day-timeframe trader. If there is an imbalance between supply and demand, it is the floor trader who must bear the brunt. For example, if there are more other-timeframe sellers than buyers, the floor trader will be faced with a situation where there is an increased supply but not enough demand to dispose of the contracts. In order to restore the equilibrium between the buyers and sellers, prices will have to be reduced to the point where they will attract buying activity.



### BUYING AND SELLING

Traders react differently to prices at different times, so it is important to recognize the type of activity that is taking place. There are two broad categories of buying and selling activities known as *initiative* and *responsive*. Differentiating between the two is

important, and the structure of Market Profile will provide clues to the type of activity taking place.

To determine which activity is taking place, you must compare the current day's profile to that of the previous day (Figure 10). If traders take the initiative to move prices higher or lower than the previous day's value area, the action indicates that the activity is initiative. If, on the other hand, selling activity is dominant when prices are higher than the previous day's value area, or buying activity prominent when prices are lower, you can conclude that responsive activity is taking place.

Comparing the current day's profile to those of previous days enables the market participant to recognize the changes from one day to the next and observe changes in market participation and attempted divergence of price from value. Such an approach will provide clues about whether the market action is occurring in a trending or bracketing (trading range) market and reveal whether movement is likely to be met with acceptance or rejection.

You can spot a trend by looking at the movement of the value area. If it moves in one clear direction, either up or down, you know that the market is in a trend. A bracketed market is one in which prices move back and forth between two price levels that act as support and resistance.

When the value area steadily moves in one direction, this means that the movement in price is being accepted. If, however, the value area is overlapping the previous value area, you can conclude that the trend is slowing down and starting to find balance. In a bracketed market, both the other-

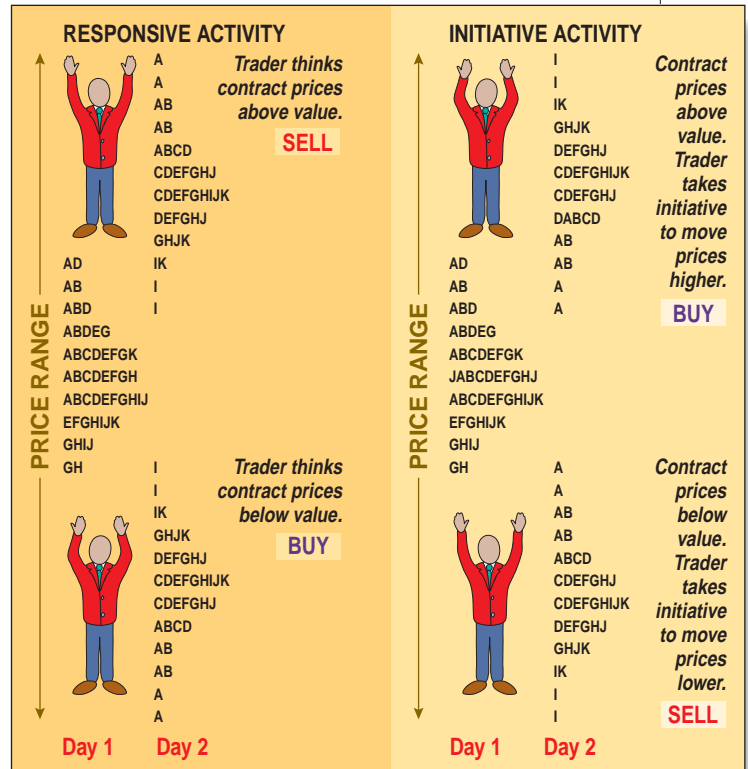

**FIGURE 10: RESPONSIVE VS. INITIATIVE ACTIVITY.** Increased selling activity when prices are above the previous day's value area, or buying activity when prices are below indicates that responsive activity is prevalent. Conversely, if increased buying activity is dominant when prices are above the previous day's value area, or selling activity prominent when prices are below, it indicates that initiative activity is prevalent.

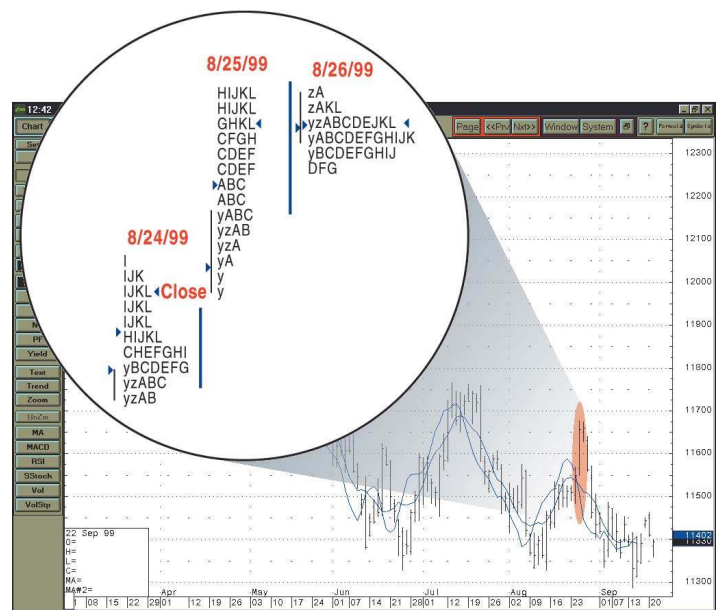

**FIGURE 11: MARKET PROFILE WITH MOVING AVERAGES.** Using Market Profile in conjunction with traditional indicators such as moving averages can supply additional confirmation. Here, moving averages alert a sell signal earlier than Market Profile, providing clues of a change in price direction.

timeframe buyers and sellers are responsive. When prices reach the top of a bracket, the seller enters and pushes them down. Conversely, when price reaches the bottom of the bracket, the buyer responds by driving them up.

To determine whether a market is bracketing or trending, I find it useful to combine Market Profile with moving averages. Figure 11 shows a bar chart of the September 1999 Treasury bond contracts with an overlay of the five- and 10-day moving averages and Market Profile of August 24 to 26, 1999.

## Market Profile reveals several factors that provide you with an idea of the trading activity taking place in the markets.

The moving average crossover methodology does a good job of indicating the trend direction and revealing good trading points. Combining it with Market Profile reveals some interesting points. The crossover of the moving averages that took place on August 24 in September T-bonds indicated a sell signal. However, with Market Profile, we can observe that the sell signal came too early; the profile does not indicate that the sellers are in control. In fact, it shows the opposite.

Since the close was above the value area, the profile of August 24 suggests that prices were likely to rise, which is precisely what happened. It is necessary to determine whether the prices will continue moving up. The profile of August 25 has a higher value area and a wider range than that of the previous day. It also shows no signs of decreased initiative activity. These factors indicate that the prices will probably keep going up.

On the profile of the following day (August 26), you can see the following:

- 1 Prices did not have much of a range and seemed to be that of a nontrend day. As mentioned previously, a nontrend day is usually followed by a change in trend.
- 2 Prices did not go above the high of the previous day.
- 3 The value area developed within that of the previous day.
- 4 Moving averages indicate an even sharper downturn.

The bar chart on Figure 11 shows that prices decreased sharply after August 26, 1999, suggesting that they hit a resistance level.

## CONCLUSION

Market Profile reveals several factors that provide you with an idea of the trading activity taking place in the markets. Monitoring the market action will enable you to determine the type of day that is developing, whether a price trend has started, what the value area is, the type of activity (initiative or responsive) taking place, whether the activity is continuing or changing from the previous day, and whether the market is trending or bracketing. Combining Market Profile with indicators such as moving averages can help you create a successful trading strategy. Next time, I'll show you more ways to apply it.

*Jayanthi Gopalakrishnan is a Staff Writer for Stocks & Commodities magazine.*

## RESOURCES AND RELATED READING

Dalton, James F., and Eric T. Jones [1995]. "Market Logic And The Market Profile: An Introduction To Technical Applications," *High Performance Futures Trading*, Joel Robbins, ed., Probus Publishing Co.

\_\_\_\_\_, \_\_\_\_\_, and Robert Dalton [1990]. *Mind Over Markets: Power Trading With Market Generated Information*, Probus Publishing Co.

Jones, Donald L. [1993]. "Commercial Floor Traders Identify Value," *Technical Analysis of STOCKS & COMMODITIES*, Volume 11: January.

\_\_\_\_\_, and Christopher J. Young [1993]. "The Overlay Profile For Current Market Analysis," *Technical Analysis of STOCKS & COMMODITIES*, Volume 11: June.

\_\_\_\_\_[1993]. *Value-Based Power Trading*, Probus Publishing Co.

Murphy, John J. [1999]. *Technical Analysis Of The Financial Markets*, New York Institute of Finance.

Williams, Ellen G. [1988]. "Trading With Steidlmayer," interview, *Technical Analysis of STOCKS & COMMODITIES*, Volume 6: June.

Market Profile is a registered trademark of the Chicago Board of Trade.

**S&C**